

## TRADITIONAL CASH RECYCLER

*Cash Recycling with Enhanced Note Handling and Authentication.*



THE WORLD LEADER IN CASH RECYCLING TECHNOLOGY WITH OVER 110,000 UNITS INSTALLED, MORE THAN ALL OTHERS COMBINED.

As the recognized global leader in cash recycling technology, Glory offers a wide range of solutions to meet the varied needs of financial institutions. Cash recycling from Glory delivers massive improvements in frontline efficiency, customer engagement and security.

All Glory recyclers are purpose-built for cash recycling applications. Performance is optimized for efficient frontline transactions as well as internal cash transactions such as vault buys and sells. With Vertera, there is reduced impact on staff for various stoppages, resulting in less

staff hassle and fewer interruptions during customer engagements. Routine daily operations can be accomplished with minimal cash exposure, fewer out-of-balance issues and write-offs. Vertera has been designed to optimize branch cash handling requirements, provide a better staff experience, and superior, uninterrupted customer engagements. Cash Recycling is enabling technology that fully supports smaller branch designs, open plan banking, universal teller concepts, cross-selling and relationship-building initiatives.



(shown with optional dual dropbox facade)

# Advantage: Glory

## Frontline Efficiency Gains

Eliminate repetitive manual cash counts and many dual control cash handling processes. Faster day-end balancing and fewer out-of-balance write-offs.

## More Secure Environment

With Vertera, all cash is securely stored in a UL-rated safe, certified for overnight currency storage. This results in reduced cash exposure, which means a safer environment for your clientele as well as staff.

## Reduced Cash Requirements

Cash deposited is immediately available for cash payments, resulting in greatly reduced idle cash in your branches. This can result in a 15-20% reduction in cash requirements.

## Less Staff Stress

Your staff will experience less stress from day-end balancing concerns and be more able to deliver efficient, customer-focused transactions.

## Improved Customer Engagements

Shorter wait times and greater staff focus mean a better overall in-branch experience and satisfied clients.

# Vertera™

## Vertera™ TECHNICAL INFORMATION

<b>Roll storage system</b>	8 Rolled Storage Modules
<b>Capacity</b>	High capacity- up to 600 notes/module
<b>Interfaces</b>	2 RS232 C serial ports 2 RS232 C, LAN/Ethernet with CashInsight Bridge
<b>Detection</b>	SDA® (Secure Document Analysis)
<b>Authenticity detectors</b>	Visible, Infrared, UV, Magnetic Ink Authenticity detectors configured to the specific currencies required
<b>Power supply</b>	100 - 240 V AC 50/60 Hz
<b>Note deposit</b>	5 notes per second, up to 300 notes per bundle
<b>Note dispense</b>	5 notes per second, up to 100 notes per bundle
<b>Remote monitoring (optional)</b>	CashInsight™ Bridge
<b>Door configurations</b>	Plain façade Manual drop deposit façade

<b>Detection</b>	SDA™ (Secure Document Analysis) Fitness configurable			
<b>Dimensions and Weight</b>	Model	Dimensions (L x W x H)	Height under desk	Weight
	Seated	35.8 x 18.3 x 32.4 in 1,070 x 465 x 823 mm	27.4 in 695 mm	948 lbs 430 kg
	Standing	35.8 x 18.3 x 42.3 in 910 x 465 x 1,100 mm	38.3 in 972 mm	1070 lbs 485 kg

<b>Options</b>	Uninterruptible power supply Connectivity to all open network architectures Dual Drop box Façade InstaChange® coin dispenser (single or dual)
----------------	--

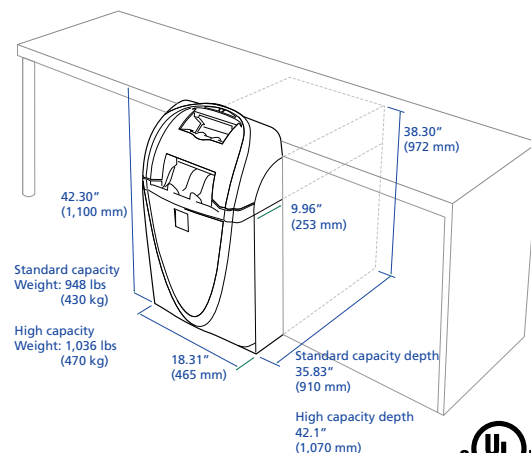

Specifications and design subject to change without notice. Please carefully read the instruction manual to ensure correct usage.



### Glory Global Solutions

3333 Warrenville Road, Suite 310 Lisle, IL 60532  
Tel: +1 (630) 577-1015  
Fax: +1 (630) 577-1270  
www.gloryglobalsolutions.com

Glory Global Solutions is part of GLORY LTD.

This document is for general guidance only. As the Company's products and services are continually being developed it is important for customers to check that the information contained herein includes the latest particulars. Although every precaution has been taken in preparation of this document, the Company and the publisher accept no responsibility for errors or omissions. The Company and the publisher accept no liability for loss or damages resulting from the use of the information contained herein. This document is not part of a contract or licence save insofar as may be expressly agreed. All capabilities and capacity and throughput figures are subject to note/coin size, note/coin quality and process used. GLORY is a registered trademark of GLORY LTD. in Japan, the United States of America, and EU. All trademarks are owned by the GLORY Limited Group of companies. © Glory Global Solutions (International) Limited 2013.